



Whole House Ventilation with Heat Recovery...



Send your plans for a
FREE ventilation design
and a competitive
quotation

- Virtually silent operation
- Low energy DC electric motors
- Range of control options
- Acoustically insulated ducting
- Filter reduces effects of respiratory allergies
- Reduces heating bills
- Can promote conditions for improved health
- Easy to install for DIYer or professional alike
- Conforms to Building regulations
- Full installation service available

...for a fresher, healthier, home

Rega's unique WhisperFlow[®] technology ensures that even when operating at full 'Boost' mode (usually during the morning bathroom rush hour!) the system remains whisper quiet - unobtrusively and effectively venting stale, damp air, replacing it with air that's been gently warmed and filtered.

Low energy DC fans, insulated ducting and a high efficiency heat exchanger also ensure that power usage and energy losses are kept to an absolute minimum.

RegaVent systems are designed and built here in the UK, to our own stringent quality assured standards, you can be sure that your RegaVent system will give you the optimum balance of a technical specification that's exactly right for the UK climate, coupled with low energy consumption - for lower heating bills!

Central Air Unit

Regavents latest range of central air units provide a new level of heat recovery efficiency with 90% heat transfer and electrical usage as low as 0.51 w/l/s.

The central air unit is the heart of the whole house heat recovery ventilation system; it houses two fans, extract and supply, a high efficiency heat exchanger plus filters for the exhaust air and fresh incoming air. The extract fan removes stale moist air from the home and the supply fan brings fresh air in to replace the extracted moist air. The AHU's are manufactured from strong, corrosion resistant galvanised steel and the plate heat exchanger is in long life plastic so the only items subject to wear are the fan motors. Now standard on all Regavent units, EC (Electronic Commutation) motors convert 240V AC power to 48V DC to give reduced energy consumption. Although the initial cost of the EC motors is higher than AC, the energy savings can recover the initial outlay within six to eight years. EC motors convert two thirds of the power used into useful work compared to only a half for AC motors. Reduced electrical losses mean lower temperatures and less thermal stress giving even longer motor life and continued electrical savings many years into the future.

Regavent units are fitted with a humidity sensor to monitor the moisture levels from all of the extract rooms. The fast response units will detect the use of a shower or bath, boosting the system to provide rapid air movement to remove the steam laden air. The active sensor only triggers to rapid changes of humidity so are not affected by the normal variations in atmospheric r.h.

Any ventilation system must be unobtrusive in operation so low noise is of great importance, to this end Regavent central units are supplied complete with an acoustic/thermal insulation jacket. Manufactured from high density close cell neoprene foam the jacket not only prevents noise breakout from the unit but also reduces heat loss to maintain thermal efficiency. To further ensure quiet operation each unit comes with a mounting cradle incorporating rubber mounts, preventing noise transmission to the structure.



SAP 2005 Appendix Q test	Regavent 250R		Regavent 300R		Regavent 600R	
Exhaust terminal configuration	Specific Fan Power (W/l/s)	Heat Recovery Efficiency (%)	Specific Fan Power (W/l/s)	Heat Recovery Efficiency (%)	Specific Fan Power (W/l/s)	Heat Recovery Efficiency (%)
Kitchen + 1 additional wet room	0.60	88	0.73	90	-	-
Kitchen + 2 additional wet room	0.62	88	0.69	89	-	-
Kitchen + 3 additional wet room	0.68	87	0.73	89	-	-
Kitchen + 4 additional wet room	0.82	86	0.80	88	0.51	90
Kitchen + 5 additional wet room	0.96	85	0.9	87	0.58	90
Kitchen + 6 additional wet room	1.13	85	1.06	87	0.68	89
Kitchen + 7 additional wet room	1.34	84	1.23	86	0.79	89

Duct Solutions

Rega Vent offer a wide range of duct solutions, allowing for installation in almost all situations.

Branched Duct Systems



- Low air flow resistance.
- Reduced material costs.
- Proven in commercial and domestic application.
- Semi-rigid aluminium and rigid spiral duct available.

Radial Duct Systems



- Smaller ducts allow for installation in limited space.
- Manifolds allow for simplified air flow control.
- Full range of manifolds and accessories.

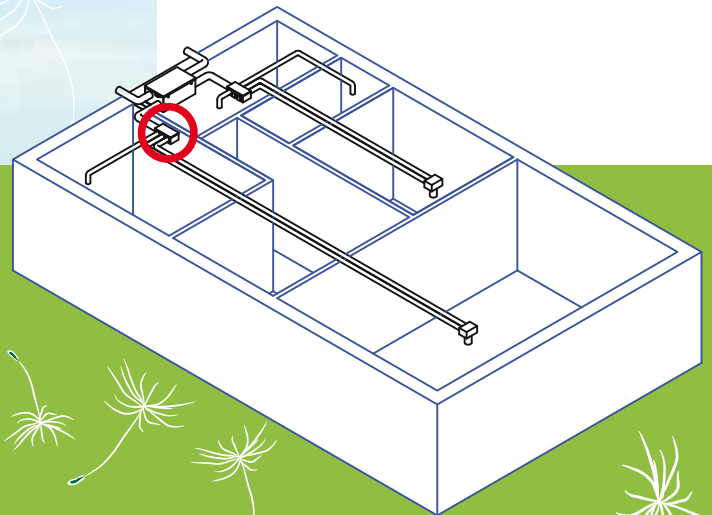
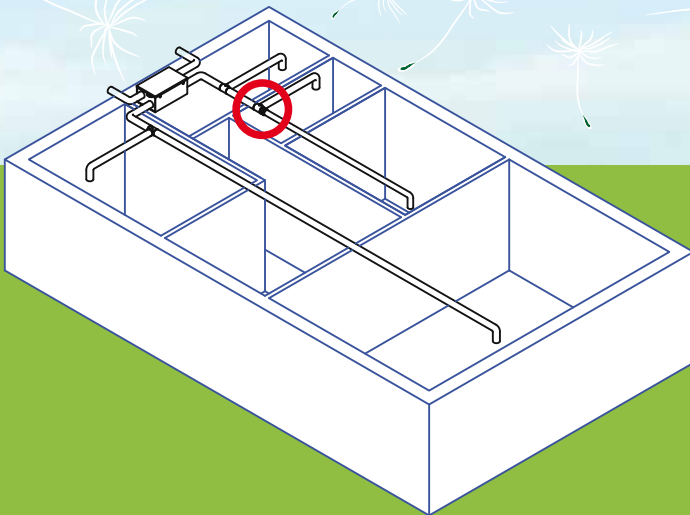

...for a fresher, healthier, home



Rega Ventilation Limited
21/22 Eldon Way, Biggleswade, Beds SG18 8NH
fax: 01767 600487 email: sales@rega-uk.com

Call us on **01767 600499** or visit
www.regavent.co.uk

Options and Extras

Summer Bypass Unit

During the summer months, it isn't necessary for the heat exchanger to be active within a system. A simple way around this is turn off the supply air fan and open windows, allowing natural ventilation to provide fresh air to the dwelling. However, if there are noise, security or allergy problems associated, then it may not be preferable to do so.

In this situation a summer bypass kit can be fitted to the unit, allowing for an automatic heat exchanger bypass. Thermostatic sensors detect the temperature of the air entering the unit, to ensure that the bypass is always in the optimal positions.

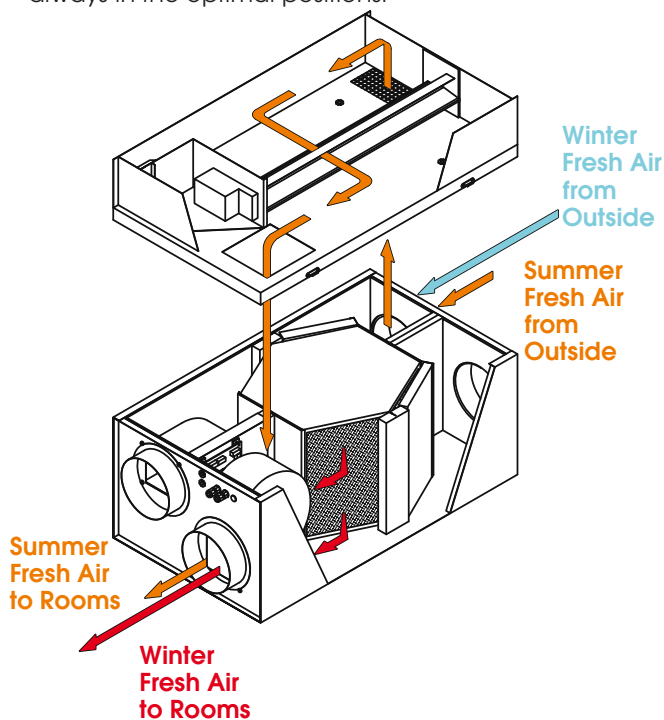

Pollen Filter

All Regavent units are fitted with filters. As standard the unit contains two G4 dust filters suitable for protecting the duct systems and increasing the quality of the incoming air. However, if there are allergy or asthma sufferers, it may be beneficial to fit the system with a separate F7 pollen filter. This will remove 99% of pollen and fine dust particles from the incoming fresh air.

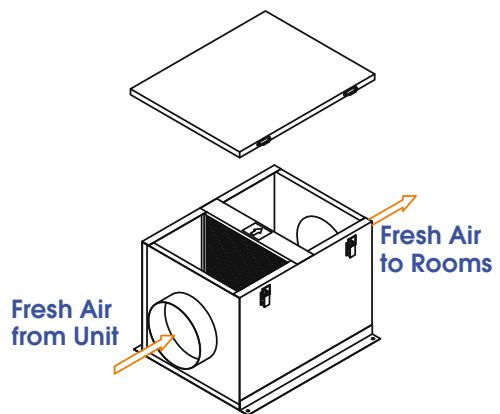

Air supply and extract grilles

Available in plastic, coated steel or stainless steel the extract and supply grilles are similar in appearance. Extract grilles incorporate washable filter elements to prevent extracted dust and particles from entering the duct system.



External connections

Grilles for mounting in vertical walls and soffits or roof terminals complete with flashing plate for slate or tile roof mounting.



Rega Ventilation Limited

21/22 Eldon Way, Biggleswade, Beds SG18 8NH

fax: 01767 600487 email: sales@rega-uk.com

Call us on **01767 600499** or visit
www.regavent.co.uk